

FANTIC

NEW ROADS

2024 RANGE WORLD PREMIERE

2019

N E W R A C I N G E R A

FANTIC
RACING



2020

GLEICH GEWINNER

EMX125

ANDREA BONACORSI

**MOTOCROSS
EUROPEAN
CHAMPION**

2 0 2 3

NUR 4 JAHREN SPÄTER EINE REICHHALTIGE
SIEGERLISTE

32

NATIONALE &
INTERNATIONALE
ERFOLGE





2023 IST DAS JAHR DES ENDURO: FANTIC HAT 5 KLASSE DER WELTMEISTERSCHAFT GEWONNEN

JUNIOR ENDURO – JUNIOR1 – JUNIOR2 - WOMEN - YOUTH

ITALIEN

SPANIEN

FINNLAND

SCHWEDEN

SLOVAKEI

PORTUGAL

PORTUGAL

6

6

10

8

6

8

8



52

ENDURO GP
SIEGE

E N D U R O



C R O S S



FANTIC
RACING

DIE EINZIGE ITALIENISCHE FIRMA, DIE
AN ALLE RENNKLASSEN TEILNIMMT

M O T O 2



R A L L Y



MX SEASON 2024

ENGAGEMENT AUF HÖCHSTER EBENE

FANTIC
RACING

MXGP



GLENN
COLDENHOFF



ROAN
VAN DE MOOSDIJK

FANTIC
RACING

MX2



DAVID
BRACERAS



KAY
KARSSEMAKERS



EIN REVOLUTIONÄRES PROJEKT,
DAS NACHHALTIGKEIT UND LEISTUNGEN
MIT STRATEGISCHEN PARTNERSCHAFTEN VERBINDET



JANE DANIELS



JEREMY MIROIR



TOMMASO MONTANARI



DER ERSTE HISTORISCHE SIEG IN DER MOTORRAD- WELTMEISTERSCHAFT



Red Bull 
RLL
S P I E L B E R G

18-20 **AUGUST** 2023

POLE UND SIEG
FÜR VIETTI

P U S H T H E
L I M I T

S T E A L T H 1 2 5
&

I M O L A C O N C E P T

NICHT EIN EINZELNES
MOTORRAD, SONDERN EINE
KOMPLETTE REIHE





125cc

A2 BEREICH

ANDERE BEREICHE

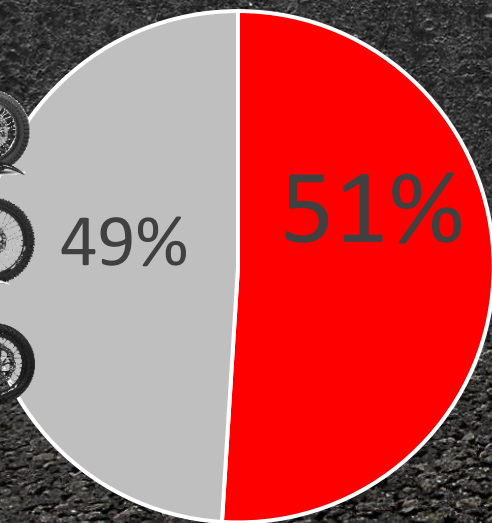

STRASSEN MOTORRÄDER

+22%

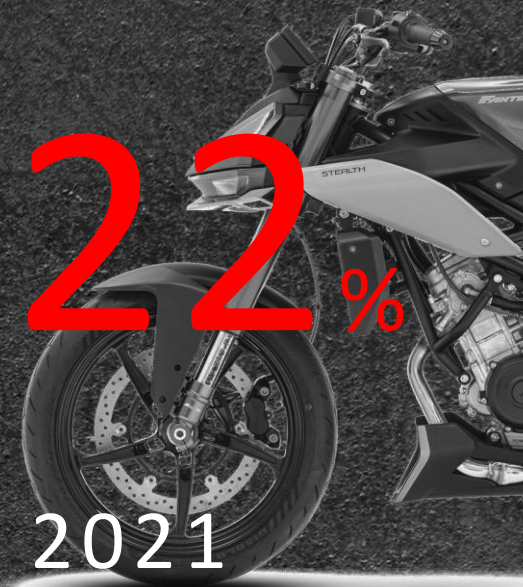

2021

VS

2023



A2



FANTIC HEADQUARTER

 SANTA MARIA DI SALA (VE)

EINE IN ITALIEN
ENTWORFENE,
AUSGEDACHTE UND
HERGESTELLTE REIHE...

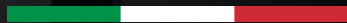

... UND WIR SIND DIE
EINZIGEN, DIE DIES FÜR
DIE A2-MOTORRÄDER TUN

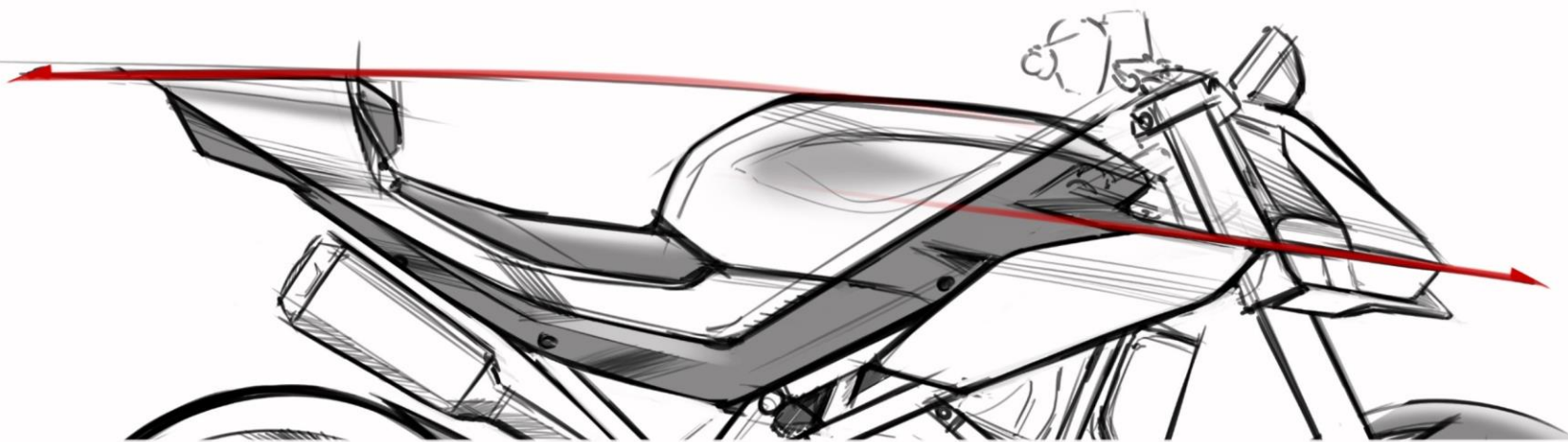
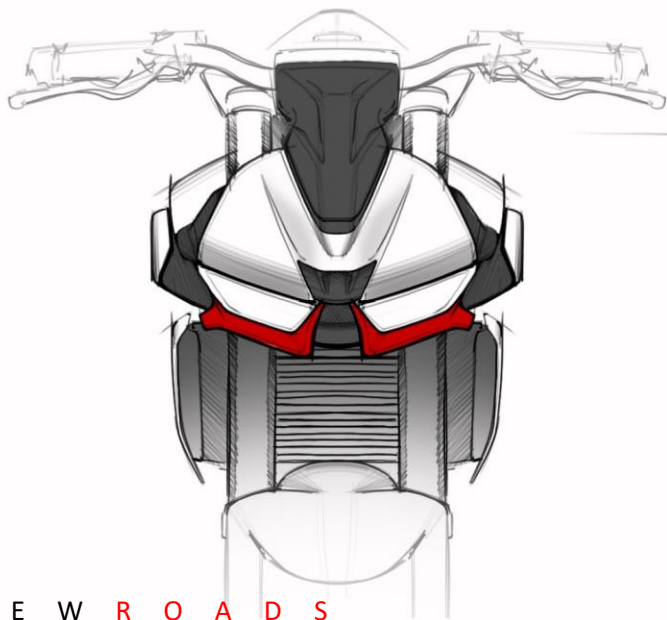
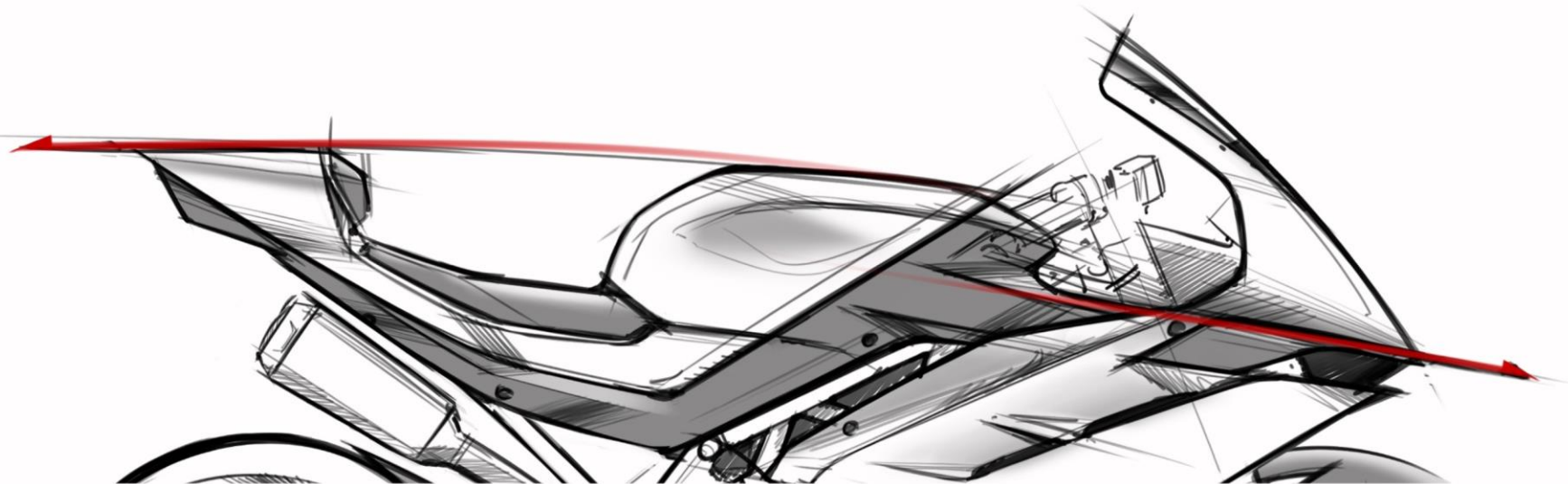
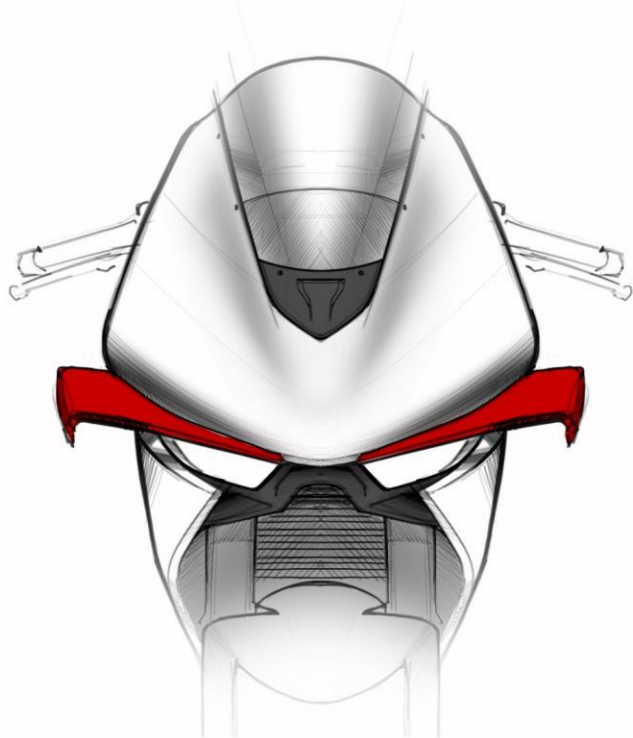

>>> MOTORRAD-WELTMEISTERSCHAFT

LAYOUT

ZENTRALISIERUNG

DER **MASSEN** →

HÖCHSTER FAHRSPASS

VORDERSEITE **AIRBOX**

TANK IN DER NÄHE
DES SCHWERPUNKTS

KAT UND **WORSCHALLDÄMPFER**
MÖGLICHTS NAHE MOTORBLOCK

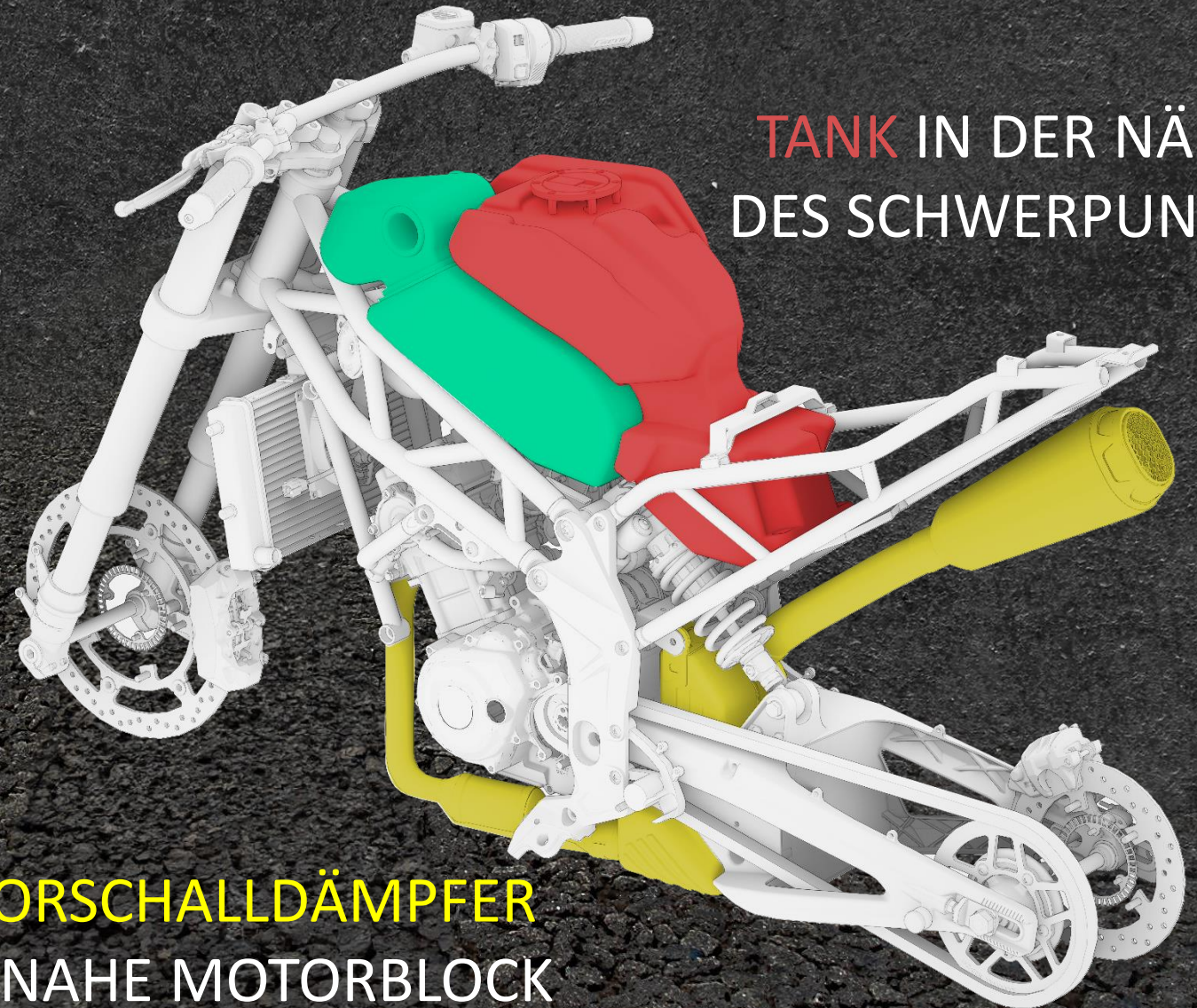

>>> FEINSTES FAHRWERK

ALUMINIUMSCHWINGE
MIT UNTERZÜGEN

GEMISCHTER
RAHMEN ZUR
OPTIMIERUN
DER STEIFIGKEIT

VORDERRAHMEN
AUS STAHL

SEITENPLATTEN AUS
ALUMINIUM

>>> EXTREME LEICHTIGKEIT

LEICHTE MOTORRÄDER UND
REDUZIERTER UNGEFEDERTEN
MASSEN

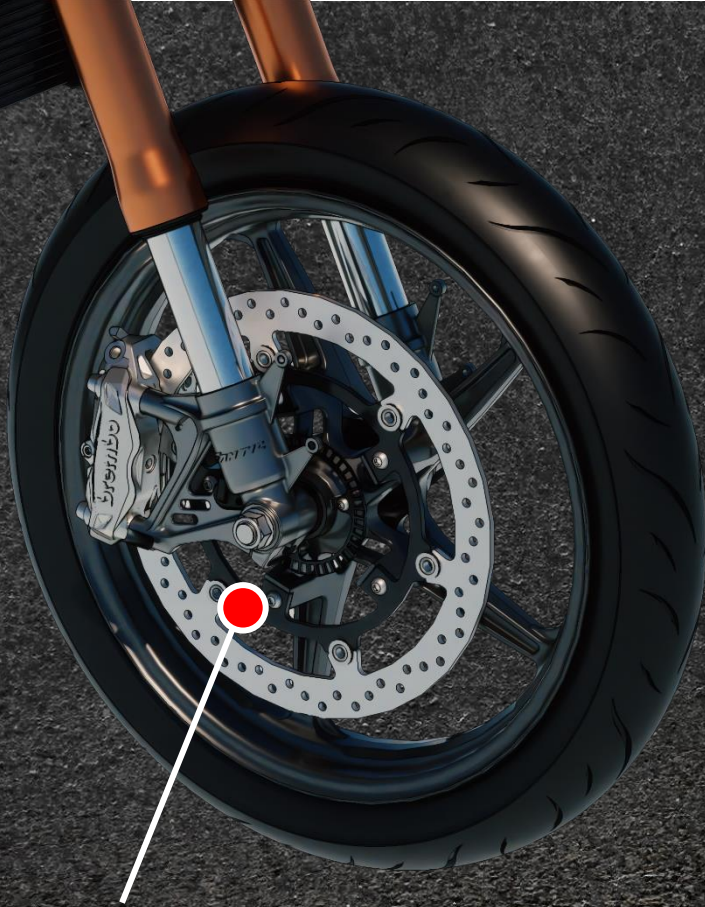

EINZELNE ABER
LEISTUNGSSTÄRKSTE
SCHEIBE



RÄDER MIT GERINGSTEM GEWICHT UND
TRÄGHEITSMOMENT SIND DIE SPITZE DER KATEGORIE

>>> MOTOR



125cc **M**otori
Minarelli

BEST IN CLASS FÜR

LEISTUNG,
DREHMOMENT &
TECHNOLOGIE

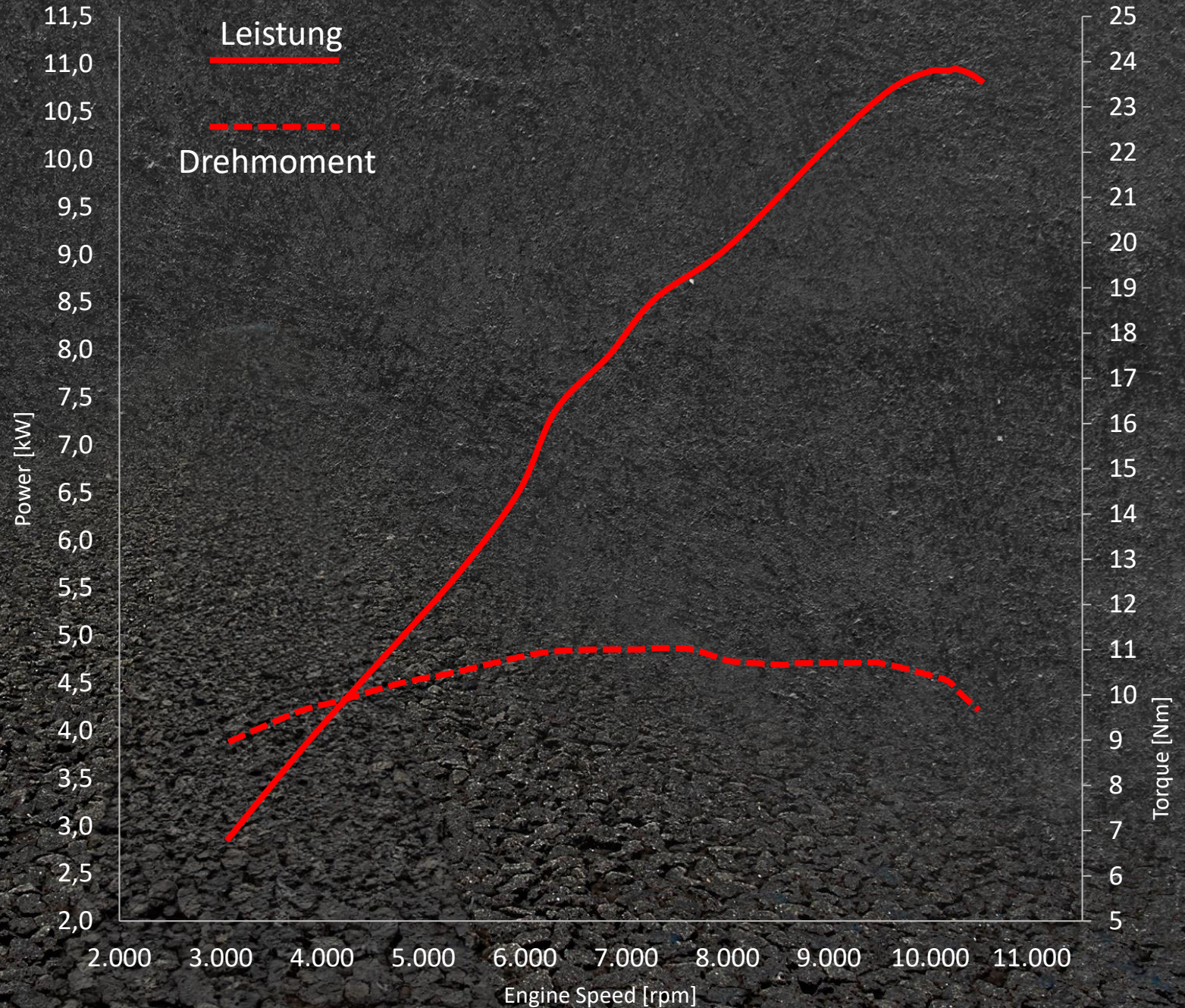

>>> ELEKTRONIK

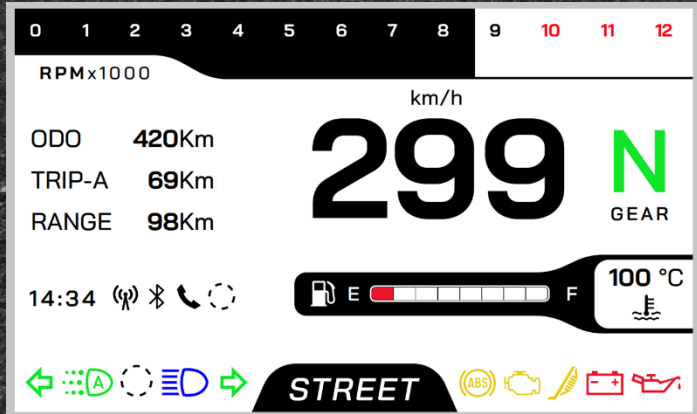

TFT 5"



TC + ABS
CORNERING



FULL LED
SCHEINWERFER

P U S H T H E
L I M I T

X E 3 0 0

XE300



XE300

EIN MOTORRAD ZUM GEWINNEN...

XXX

... DAS SCHON GEWONNEN HAT!

ALBIN NORRBIN

JUNIOR2 WORLD CUP
WINNER

enduro
GP
FIM WORLD CHAMPIONSHIP



XE300

EINE LANGE UND DETAILLIERTE
ENTWICKLUNG

× × ×

× × ×

2022



DAVIDE
GUARNERI

2023



ALBIN
NORRBIN

HEUTE

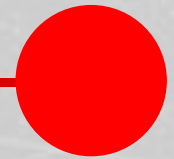

BEREIT FÜR
ERSTELLUNG

XE300

FANTIC FLAGSHIP



LEISTUNG



MM300cc

DER LEISTUNGSSTÄRKSTE
MOTOR **AUF DEM MARKT**

DER EINZIGE 300 2T MIT
ALUMINIUMRAHMEN

**TRACTION CONTROL +
DOUBLE MAP SWITCH**

**NEUGESTALTETES
KÜHLSYSTEM**

FUNKTIONALITÄT



HYDRAULISCHE KUPPLUNG

**DIREKTEN ZUGRIFF
ZUM LUFTFILTER**

**HOCHMODERNE
HANDLEBAR SWITCHES**

ERGONOMIE



MASSEN ZENTRALISIERUNG
AUF **KLEINSTEM RAUM:**

**INTEGRIERTE ÖL- UND
BENZINTANK**

NEUGESTALTETE HINTERACHSE

**ENGE UND ERGONOMISCHE
FÖDERANLAGEN**



GLEICHBLEIBENDE LEISTUNGEN



NEUGESTALTETES KÜHLSYSTEM

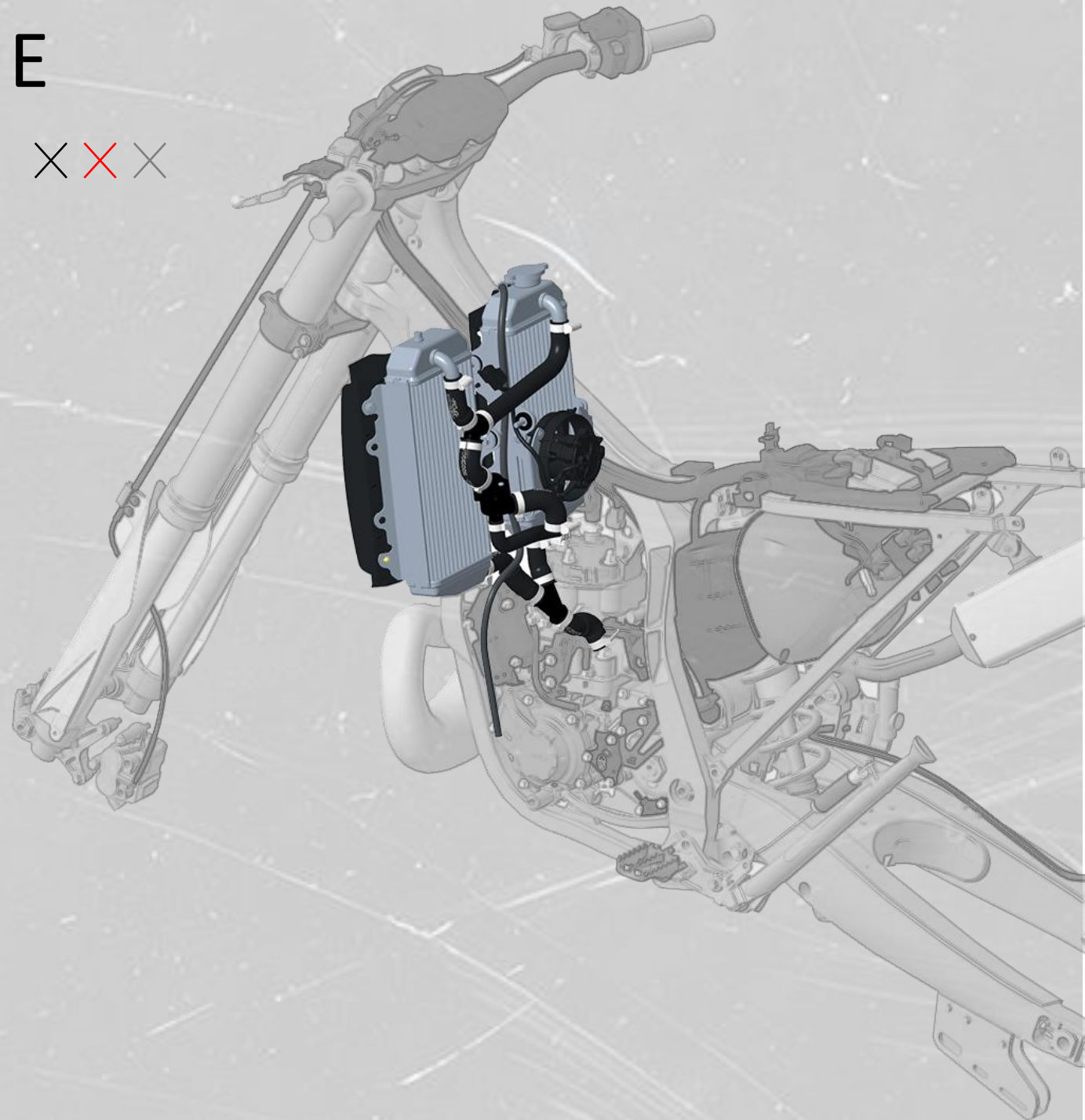

KONFIGURAZIONSLED



DOUBLE
MAP SWITCH

MULTILEVEL
TC SETTINGS

× × ×

× × ×

XE300

FANTIC FLAGSHIP



MINIMALES UND FUNKTIONALES
KILL SWITCH

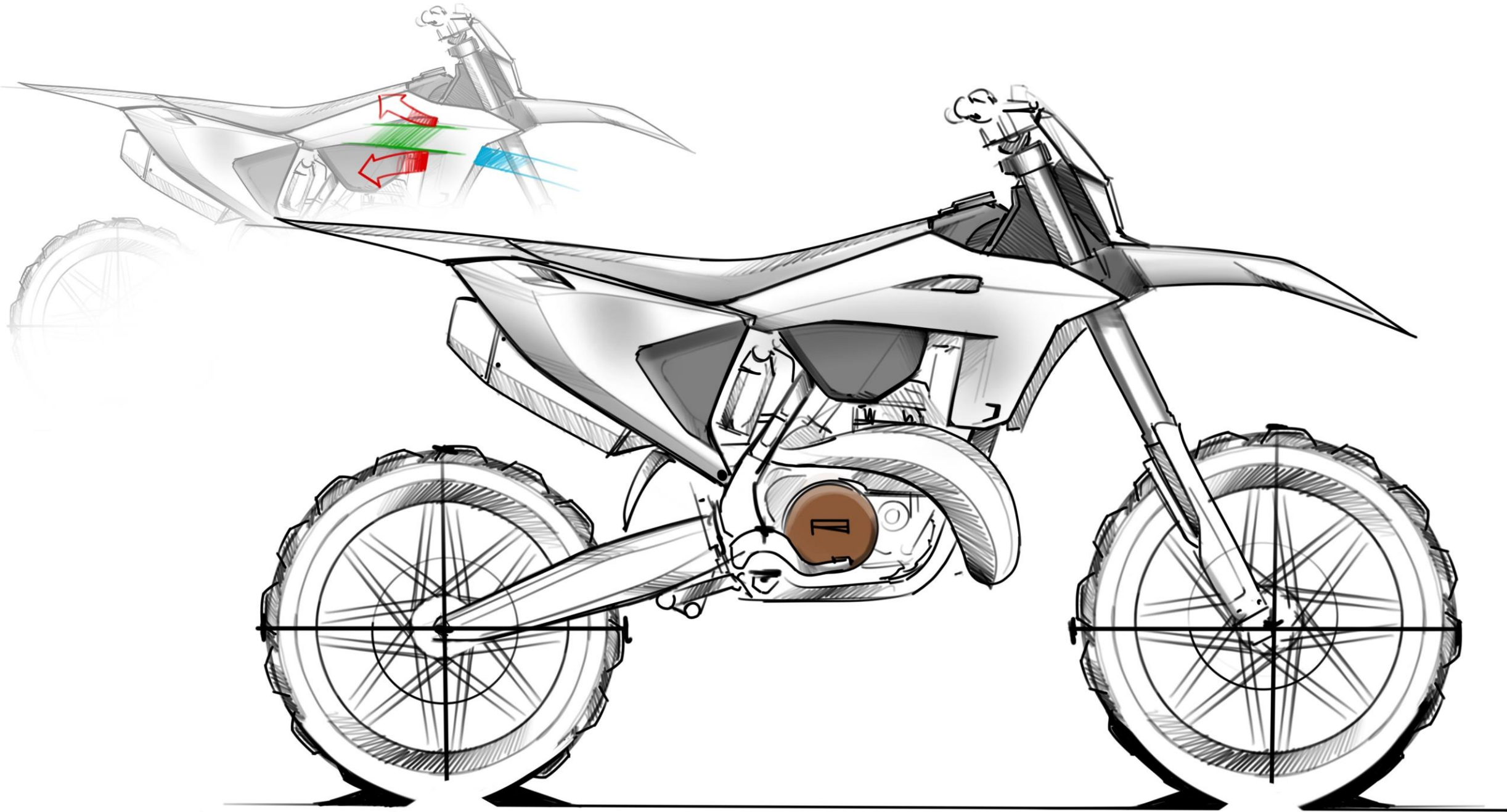

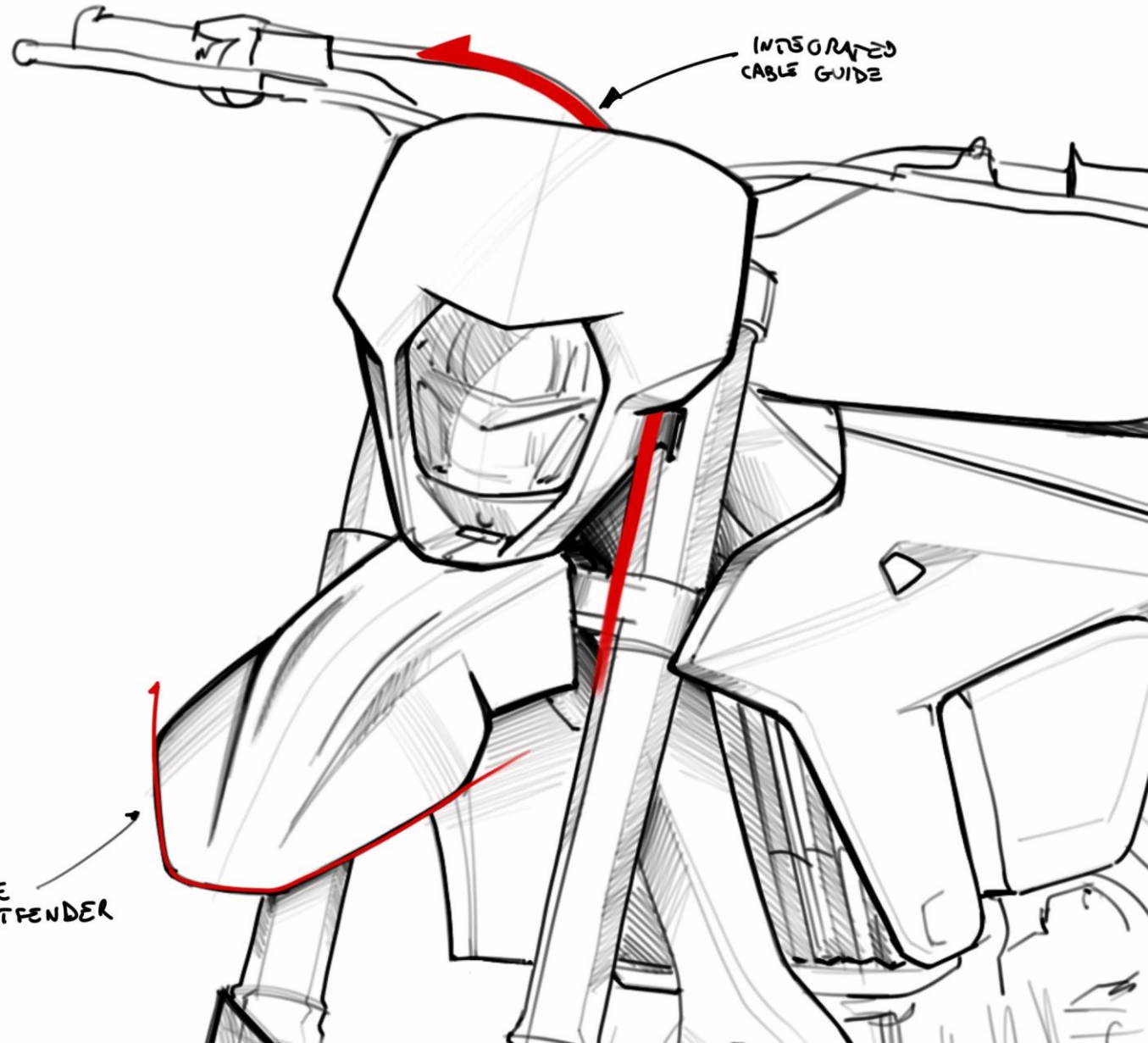
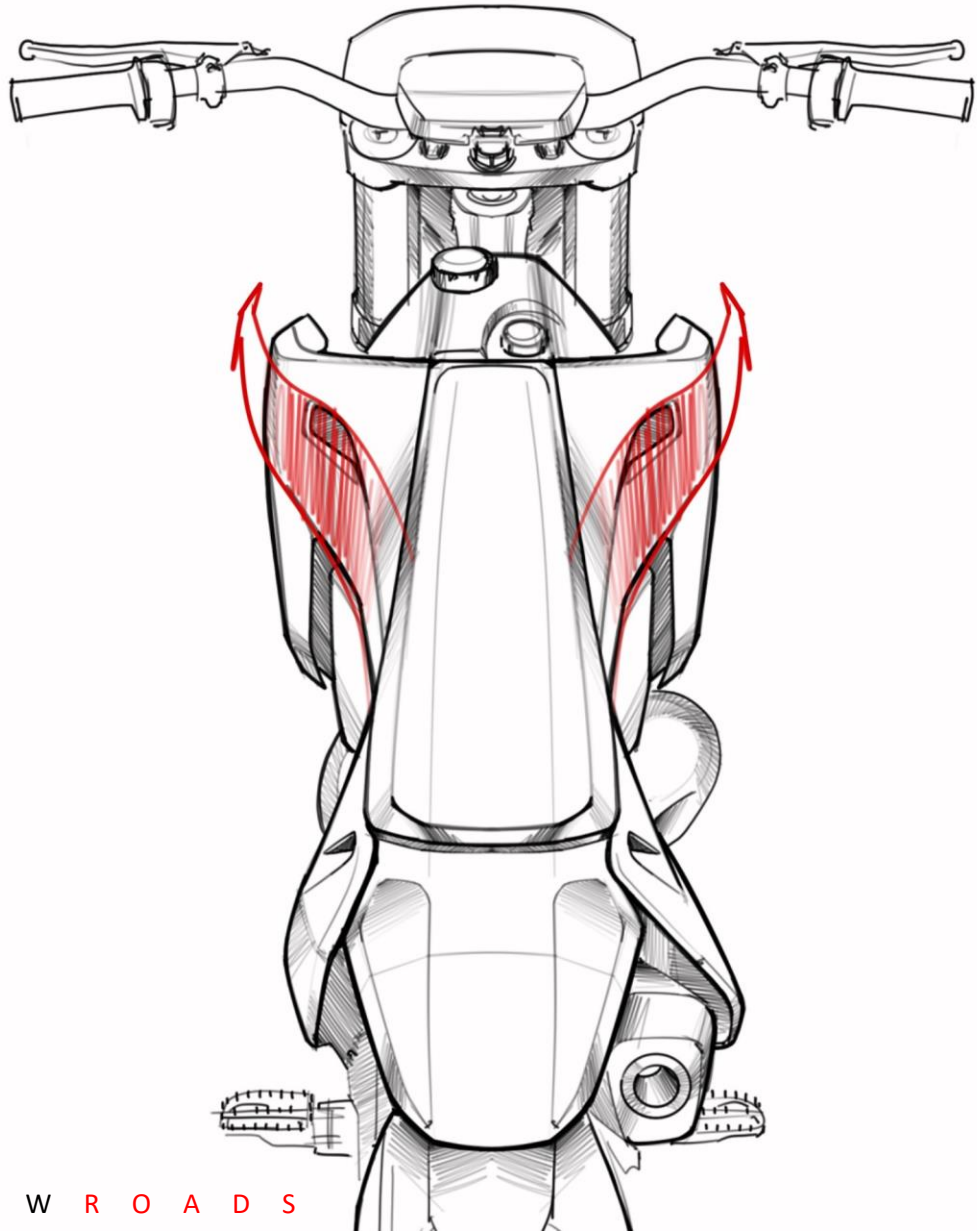



PERFEKTE ERGONOMIE



**INTEGRIERTE ÖL-
UND BENZINTANK**



**SCHLANKES HECK: WIE BEI
DER 125, ABER MIT
INTEGRIERTE
STEUERELEKTRONIK**



DER ERSTE ENTWICKELTE, GETESTETE UND HERGESTELLTE **IN ITALIEN** IN **MOTORI MINARELLI RACING MOTOR**

- M** KOMPAKT
- M** TECHNOLOGISCH
- M** LEISTUNGSSTARK

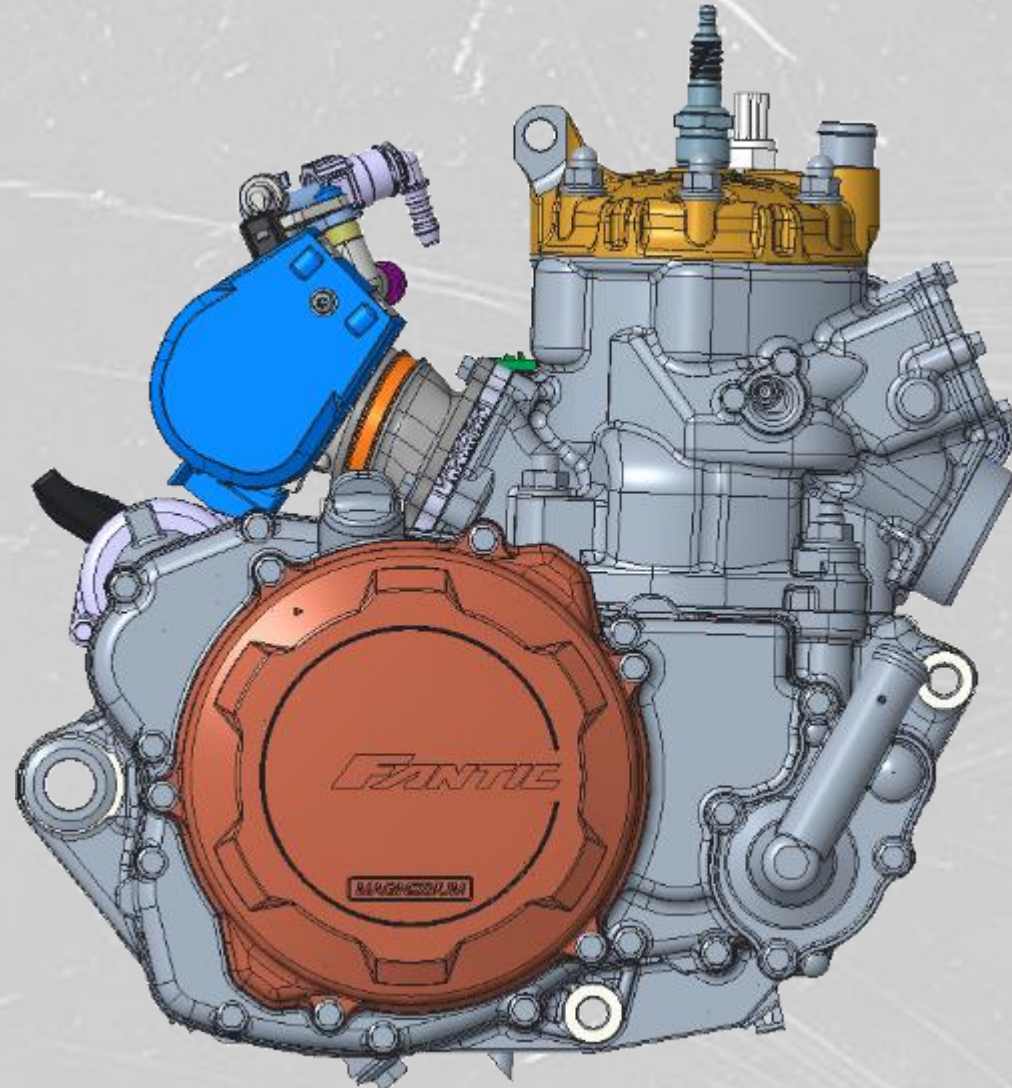

XEF310

THE PERFECT BALANCE



XEF310

THE PERFECT BALANCE

×××

×××



250
SPASS &
AGILITÄT



450
DREHMOMENT
&
LIEFERUNG



SWEET PERFORMANCE

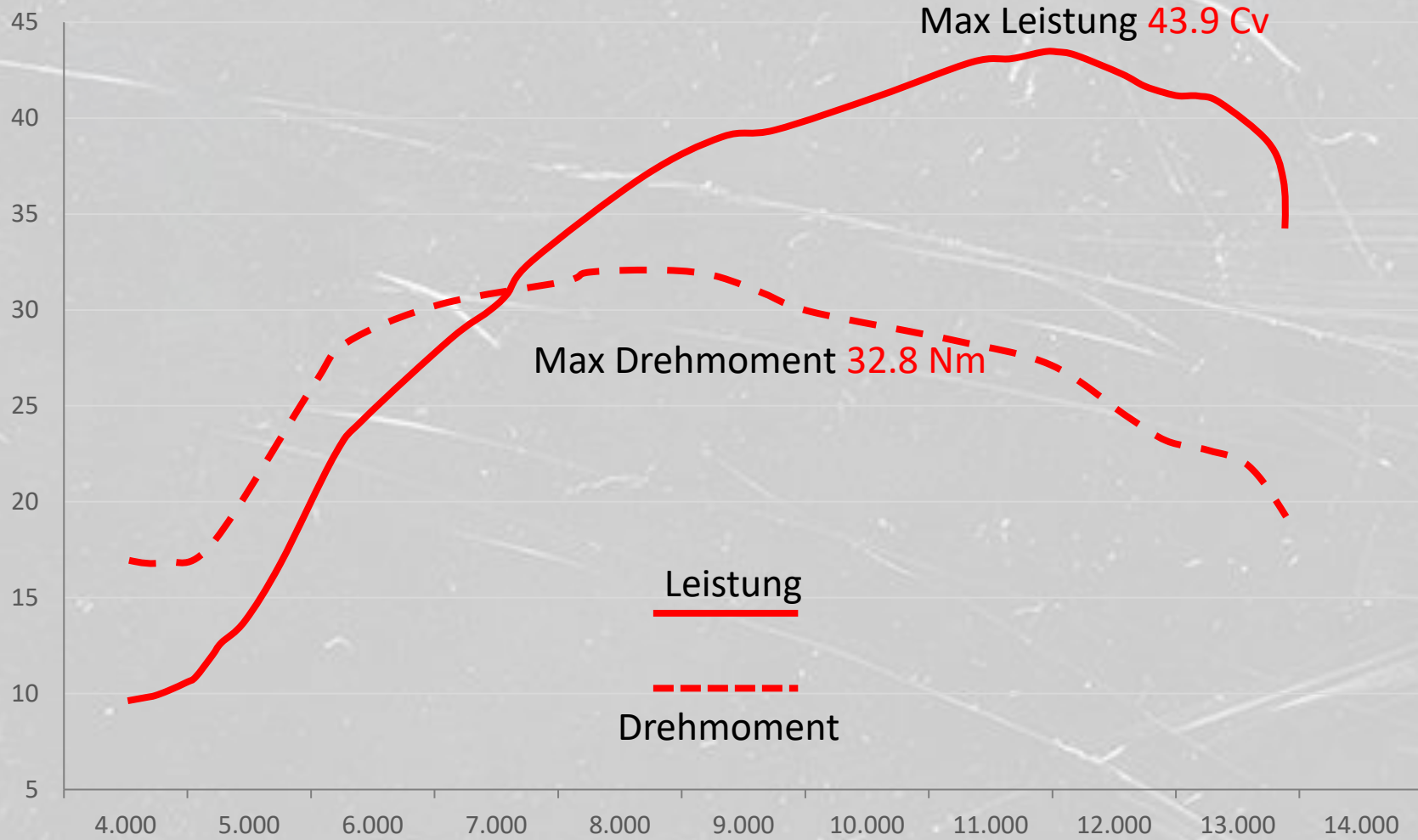



SWEET PERFORMANCE



PERFEKTE LEISTUNG FÜR
ENDURO DANK:

EIGENE ZYLINDER UND
KOLBEN

3 AUSWÄHLBARE
MOTORLEISTUNGSABBILDUNGEN



XEF310

VIEL MEHR

XXX



NEUE HANDLEBAR
SWITCHES

XXX



TC+
ENGINE MAPS

EIGENE DÄMPFER
EINSTELLUNGEN

XXX

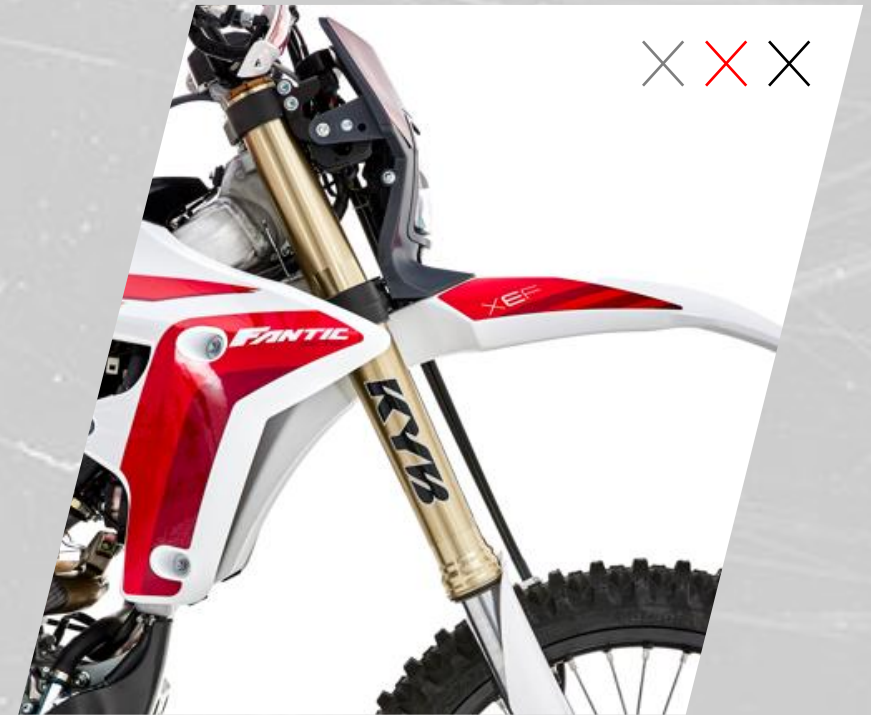

FANTIC
ELECTRIC

JOIN THE
REVOLUTION



NEW ROADS



FANTIC
ELECTRIC

eMOTARD

CONCEPT

XM 50 2T

FANTIC

ANALOG



FESSELND

MECHANISCH

GROSSE REICHWEITE

EINE WEITERE ZUKUNFT IST MÖGLICH

eMOTARD

FANTIC
FANTIC

DIGITAL



UNMITTELBAR

WENDIG

URBANPROOF

LUSTIG

DIREKT
45 Nm PEAK



AGIL

95kg



SMART

>130km Range
Handschuhfach
& Ladegerät



CABALLERO

DAS **PERFEKTE**
SCRAMBLER





EINZIGARTIG AUF DEM MARKT

FUN



THE CABALLERO SWEET SPOT

ROAD

OFFROAD



TRAVEL

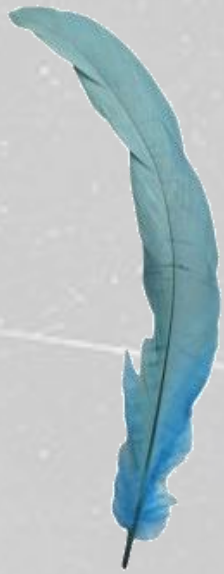

149_{KG}



AUS VIELEN GRÜNDEN
EINZIGARTIG...

-20_{KG} VS DEN LEICHTSTEN WETTBEWERBER



ICON



OFFROAD FUN



... ABER MIT VIELEN NUANCEN

ABENTEUR



URBAN SOUL





TECHNIK



STYLE



CABALLERO MY24

360° UPGRADE

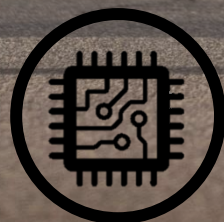

ELEKTRONIK



STYLE

CABALLERO

MY24



NEUE FULL LED
FRONTSCH EINWERFER UND BLINKER



ICONISCHES LED-RÜCKLICHT
MIT INNOVATIVEM DESIGN
VERKÜRZTER **KENNZEICHENHALTER**

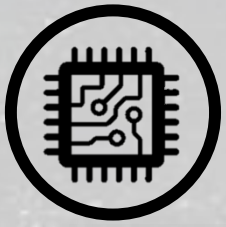

ELETTRONIK

CABALLERO

MY24



LCD BONDED INTERFACE
3,5" MIT BLUETOOTH
REICHTER USER INTERFACE

NEUE UND UMFANGREICHE
LENKER-SCHALTER



TECHNIK

CABALLERO

MY24





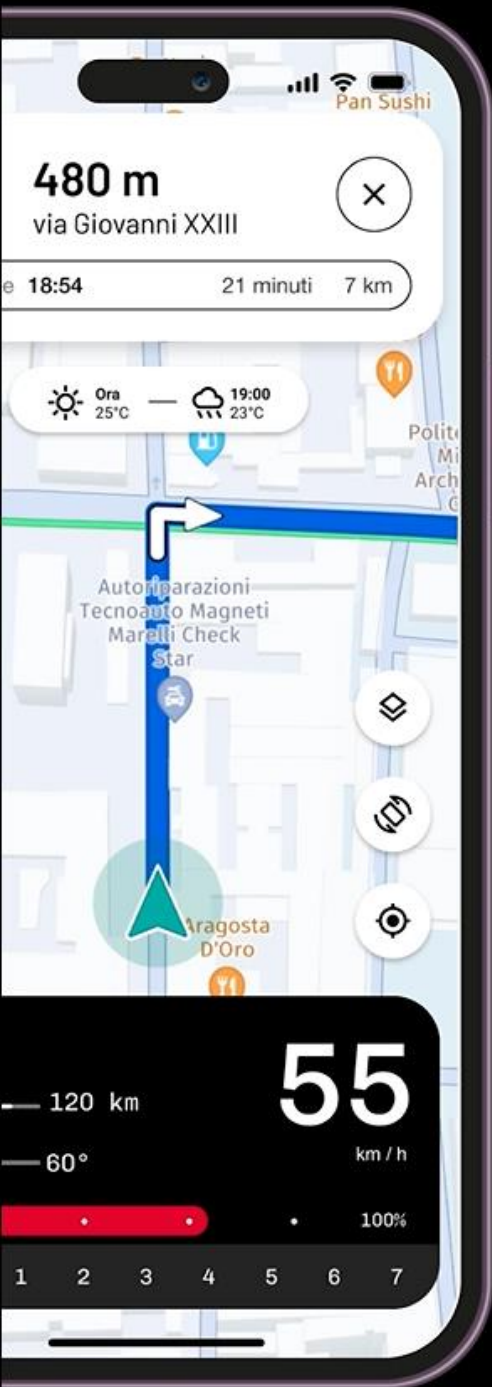

NEUE ALUMINIUMSCHWINGE: LINEARE LEISTUNGSENTFALTUNG
-2KG VS STAHL

DURCH
GRÖSSERES SCHWUNGRAD +
NEUEM MAPPING



FANTIC GARAGE APP

-  NAVIGATION
-  TRIP RECORD
-  VIRTUAL DASHBOARD
-  FAHRZEUGSYSTEMMANAGER